

# Active Fin Stabilizers

Models 162, 174, 252, 254, 302, 320, 360, 420, 525

575, 621, 720, 820, 925, 1050, 1200 & 1400

*The industry standard for superior performance, quality, reliability, long-term support and overall value. NAIAD® Stabilizers are the equipment of choice installed in thousands of vessels in demanding commercial and military ship applications as well as luxury yachts of all sizes.*

*With more systems in service than any other brand, Naiad Dynamics product designs are a refined evolution earned from real-life experience, analysis, and constant development. Install Naiad, Instill Confidence™*

## Fin Actuator Assembly Features

- ✓ Highest quality materials and workmanship. Major components machined to US military standards in our ISO 9001:2015 certified facility alongside aerospace machined parts.
- ✓ Industry first heavy-duty tapered roller bearing construction. Designed for life; no main bearing replacement required. Compare to inexpensive and wear-prone plain bearings/bushings.
- ✓ Factory assembled and tested. No disassembly required at installation.
- ✓ Double lower shaft seals encased in an easily accessible precision-machined stainless steel housing.
- ✓ Proven hydrodynamically-efficient foil section designs. Tip fence (shown), proportionately sized and validated for performance.
- ✓ Advanced composite fin construction is galvanically inert and features an encapsulated stainless steel insert with precision machined self-locking keyless taper.

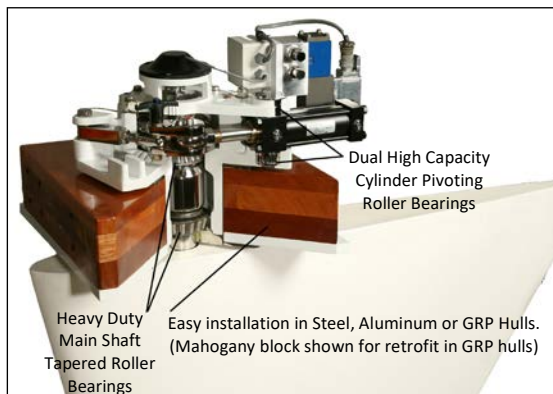
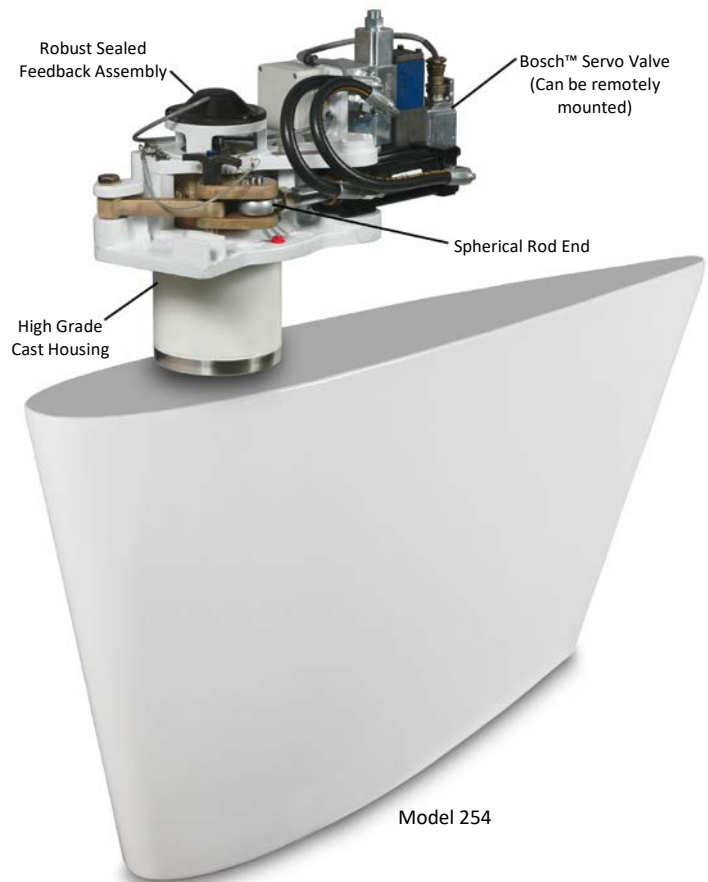

- ✓ Keyless taper allows freedom to install the NAIAD Assembly in any 360° orientation to simplify installation and maximize accessibility, plus allows the fins to be aligned and realigned in any desired position to suit hull flow lines.
- ✓ Robust fin construction is damage resistant, but designed to yield safely to severe impacts.
- ✓ First choice among discriminating yacht owners and ship builders throughout the world.

## Electronic Control Systems

- ✓ Advanced & proven fully proportional automatic Angle-Velocity-Acceleration (AVA™) closed loop control systems for maximum roll reduction performance in any seaway with minimum drag.
- ✓ Standard MultiSea™ II control system (shown at right), optional DATUM™ (graphical display panel options at far right, each with intuitive multi-page display screens)
- ✓ Resonant roll reduction typically 90%. Static heel correction. Sensitivity adjustment. Automatic fin limiting and centering. DATUM Adaptive Technology self-tunes to optimize performance.
- ✓ Enhanced course-keeping, reduced rudder drag typically improves overall destination time and fuel efficiency.
- ✓ DATUM is the world's first purely digital fin stabilizer control system operating on a CANbus distributed network.



## Hydraulic Systems

Complete hydraulic systems standard or tailored for specific applications. From simple fixed-displacement pump systems to advanced PLC controlled systems that efficiently integrate all shipboard hydraulic equipment. Our specialist hydraulic engineers specify all necessary components, source and oversee in-house testing, and supply fully detailed drawings. Naiad's standard range of quiet Powerpacks are also available to power hydraulic systems.

## Outstanding Service and Support

Naiad Dynamics stands behind every system sold with its superb Limited Warranty. NAIAD® products are supported worldwide by our six sales and service centers and mobile fleet, and by our comprehensive Authorized Dealer Network with locations in key yachting regions for fastest response and guaranteed satisfaction. Spare parts are usually in-stock and ship within 24 hours, and our state-of-the-art in-house manufacturing facility ensures quick turnaround on parts throughout the life of the system.

## Application Guidelines (this Series)

Naiad Model	OAL Feet (Meters)	Max Displacement (Approx)	Fin Sizes Sq. Feet (Sq. M.)
162	30 - 42 (9 - 13)	25 S. Tons (23 M Tons)	3 - 4.5 (0.28 - 0.42)
174-1	32 - 50 (10 - 15)	35 S. Tons (32 M Tons)	3 - 6 (0.28 - 0.56)
252	45 - 75 (13 - 23)	50 S. Tons (45 M Tons)	3 - 7.5 (0.28 - 0.70)
254	55 - 85 (16 - 26)	80 S. Tons (73 M Tons)	3 - 9 (0.28 - 0.84)
302	80 - 100 (24 - 31)	140 S. Tons (130 M Tons)	4.5 - 12 (0.42 - 1.12)

### NAIAD DYNAMICS US, INC.

Connecticut, USA  
+1 203 929 6355

Maryland, USA  
+1 301 690 2010

Florida, USA  
+1 954 797 7566

### NAIAD DYNAMICS UK LIMITED

Southampton, England  
+44 (0) 2392 53 9750

### NAIAD DYNAMICS HOLLAND, BV

Maastricht, Netherlands  
+31 (0) 43 604 9200

### ND ASIA PACIFIC PTY. LIMITED

Perth, Australia  
+61 (0) 451 699 676



www.naiad.com  
sales@naiad.com

**NAIAD DYNAMICS: The Science of Stabilization®**